

Features

- Low power consumption
- Low voltage drop
- Low temperature coefficient
- High input voltage (up to 24V)
- High output current: 100 mA ($P_d \leq 250\text{mW}$)
- TO-92 and SOT-89 package

Applications

- Battery-powered equipment
- Communication equipment
- Audio/Video equipment

General Description

The HT75XX series is a set of three-terminal high current low voltage regulator implemented in CMOS technology. They can deliver 100mA output current and allow an input voltage as high as 24V. They are available with several fixed output voltages ranging from 3.0V to 8V. CMOS technology ensures low voltage drop and low quiescent current.

Although designed primarily as fixed voltage regulators, these devices can be used with external components to obtain variable voltages and currents.

Selection Table

Part No.	Output Voltage	Tolerance
HT7530	3.0V	±5%
HT7533	3.3V	±5%
HT7536	3.6V	±5%
HT7544	4.4V	±5%
HT7550	5.0V	±5%
HT7580	8.0V	±5%

Block Diagram

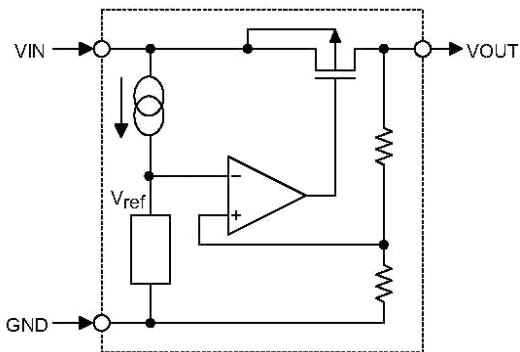

Pin Assignment

TO-92

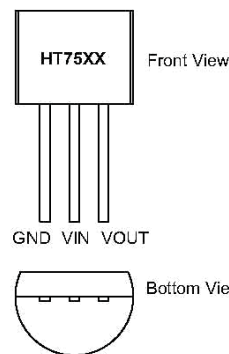

SOT-89

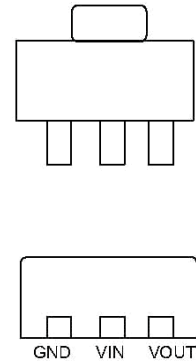

Pad Assignment

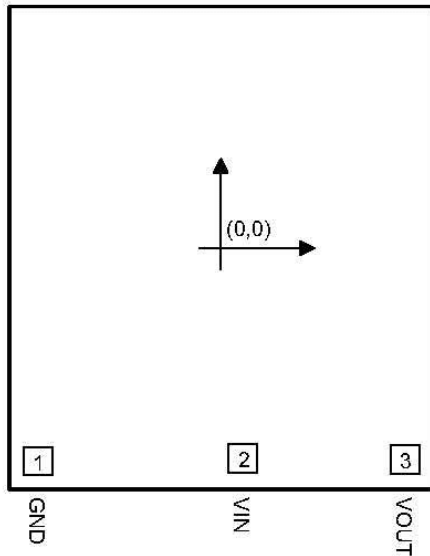

Pad Coordinates

Unit: μm

Pad No.	X	Y
1	-506.50	-589.50
2	61.00	-582.50
3	510.50	-585.50

Chip size: $1390 \times 1530 (\mu\text{m})^2$

*The IC substrate should be connected to V_{DD} in the PCB layout artwork.

Absolute Maximum Ratings

Supply Voltage.....-0.3V to 26V
 Power Consumption.....250mW

Storage Temperature.....-50 to 125
 Operating Temperature..... 0 to 70

Note: These are stress ratings only. Stresses exceeding the range specified under “Absolute Maximum Rating” may cause substantial damage to the device. Functional operation of this device at other conditions beyond those listed in the specification is not implied and prolonged exposure to extreme conditions may affect device reliability.

Electrical Characteristics

HT7530, +3.0V output type

$T_a=25$

Symbol	Parameter	Test Conditions		Min.	Typ.	Max.	Unit
		V_{IN}	Conditions				
V_{OUT}	Output Voltage Tolerance	5V	$I_{OUT}=10\text{mA}$	2.85	3.0	3.15	V
I_{OUT}	Output Current	5V	-	60	100	-	mA
V_{OUT}	Load Regulation	5V	$1\text{mA} \leq I_{OUT} \leq 50\text{mA}$	-	60	150	mV
V_{DIF}	Voltage Drop	-	$I_{OUT}=1\text{mA}$	-	100	-	mV
I_{SS}	Current Consumption	5V	No load	-	10	20	μA
$\frac{\Delta V_{OUT}}{\Delta V_{IN} \times V_{OUT}}$	Line Regulation	-	$4\text{V} \leq V_{IN} \leq 12\text{V}$ $I_{OUT}=1\text{mA}$	-	0.2	-	%/V
V_{IN}	Input Voltage	-	-	-	-	24	V
$\frac{\Delta V_{OUT}}{\Delta T_a}$	Temperature Coefficient	5V	$I_{OUT}=10\text{mA}$ $0 < T_a < 70$	-	± 0.45	-	mV/

HT7533, +3.3V output type

Ta=25

Symbol	Parameter	Test Conditions		Min.	Typ.	Max.	Unit
		V _{IN}	Conditions				
V _{OUT}	Output Voltage Tolerance	5.5V	I _{OUT} =10mA	3.14	3.3	3.47	V
I _{OUT}	Output Current	5.5V	-	60	100	-	mA
V _{OUT}	Load Regulation	5.5V	1mA ≤ I _{OUT} ≤ 50mA	-	60	150	mV
V _{DIF}	Voltage Drop	-	I _{OUT} =1mA	-	100	-	mV
I _{SS}	Current Consumption	5.5V	No load	-	10	20	μA
$\frac{\Delta V_{OUT}}{\Delta V_{IN} \times V_{OUT}}$	Line Regulation	-	4.5V ≤ V _{IN} ≤ 12V I _{OUT} =1mA	-	0.2	-	%/V
V _{IN}	Input Voltage	-	-	-	-	24	V
$\frac{\Delta V_{OUT}}{\Delta T_a}$	Temperature Coefficient	5.5V	I _{OUT} =10mA 0 < Ta < 70	-	±0.5	-	mV/

HT7536, +3.6V output type

Ta=25

Symbol	Parameter	Test Conditions		Min.	Typ.	Max.	Unit
		V _{IN}	Conditions				
V _{OUT}	Output Voltage Tolerance	5.6V	I _{OUT} =10mA	3.42	3.6	3.78	V
I _{OUT}	Output Current	5.6V	-	60	100	-	mA
V _{OUT}	Load Regulation	5.6V	1mA ≤ I _{OUT} ≤ 50mA	-	60	150	mV
V _{DIF}	Voltage Drop	-	I _{OUT} =1mA	-	100	-	mV
I _{SS}	Current Consumption	5.6V	No load	-	10	20	μA
$\frac{\Delta V_{OUT}}{\Delta V_{IN} \times V_{OUT}}$	Line Regulation	-	4.6V ≤ V _{IN} ≤ 12V I _{OUT} = 1 mA	-	0.2	-	%/V
V _{IN}	Input Voltage	-	-	-	-	24	V
$\frac{\Delta V_{OUT}}{\Delta T_a}$	Temperature Coefficient	5.6V	I _{OUT} = 10mA 0 < Ta < 70	-	±0.6	-	mV/

HT7544, +4.4V output type

Ta=25

Symbol	Parameter	Test Conditions		Min.	Typ.	Max.	Unit
		V _{IN}	Conditions				
V _{OUT}	Output Voltage Tolerance	6.4V	I _{OUT} =10mA	4.18	4.4	4.62	V
I _{OUT}	Output Current	6.4V	-	60	100	-	mA
V _{OUT}	Load Regulation	6.4V	1mA ≤ I _{OUT} ≤ 50mA	-	60	150	mV
V _{DIF}	Voltage Drop	-	I _{OUT} =1mA	-	100	-	mV
I _{SS}	Current Consumption	6.4V	No load	-	10	20	μA
$\frac{\Delta V_{OUT}}{\Delta V_{IN} \times V_{OUT}}$	Line Regulation	-	5.4V ≤ V _{IN} ≤ 12V I _{OUT} =1mA	-	0.2	-	%/V
V _{IN}	Input Voltage	-	-	-	-	24	V
$\frac{\Delta V_{OUT}}{\Delta T_a}$	Temperature Coefficient	6.4V	I _{OUT} =10mA 0 < Ta < 70	-	±0.7	-	mV/

HT7550, +5.0V output type

Ta=25

Symbol	Parameter	Test Conditions		Min.	Typ.	Max.	Unit
		V _{IN}	Conditions				
V _{OUT}	Output Voltage Tolerance	7V	I _{OUT} =10mA	4.75	5.0	5.25	V
I _{OUT}	Output Current	7V	-	100	150	-	mA
V _{OUT}	Load Regulation	7V	1mA ≤ I _{OUT} ≤ 70mA	-	60	150	mV
V _{DIF}	Voltage Drop	-	I _{OUT} =1mA	-	100	-	mV
I _{SS}	Current Consumption	7V	No load	-	10	20	μA
$\frac{\Delta V_{OUT}}{\Delta V_{IN} \times V_{OUT}}$	Line Regulation	-	6V ≤ V _{IN} ≤ 15V I _{OUT} =1mA	-	0.2	-	%/V
V _{IN}	Input Voltage	-	-	-	-	24	V
$\frac{\Delta V_{OUT}}{\Delta T_a}$	Temperature Coefficient	7V	I _{OUT} =10mA 0 < Ta < 70	-	±0.75	-	mV/

HT75580, +8.0V output type

Ta=25

Symbol	Parameter	Test Conditions		Min.	Typ.	Max.	Unit
		V _{IN}	Conditions				
V _{OUT}	Output Voltage Tolerance	10V	I _{OUT} =10mA	7.61	8.0	8.4	V
I _{OUT}	Output Current	10V	-	100	150	-	mA
V _{OUT}	Load Regulation	10V	1mA ≤ I _{OUT} ≤ 70mA	-	60	150	mV
V _{DIF}	Voltage Drop	-	I _{OUT} =1mA	-	100	-	mV
I _{SS}	Current Consumption	10V	No load	-	10	20	μA
$\frac{\Delta V_{OUT}}{\Delta V_{IN} \times V_{OUT}}$	Line Regulation	-	9V ≤ V _{IN} ≤ 20V I _{OUT} =1mA	-	0.2	-	%/V
V _{IN}	Input Voltage	-	-	-	-	24	V
$\frac{\Delta V_{OUT}}{\Delta T_a}$	Temperature Coefficient	10V	I _{OUT} =10mA 0 < Ta < 70	-	±1.2	-	mV/

Application Circuits

Basic circuit

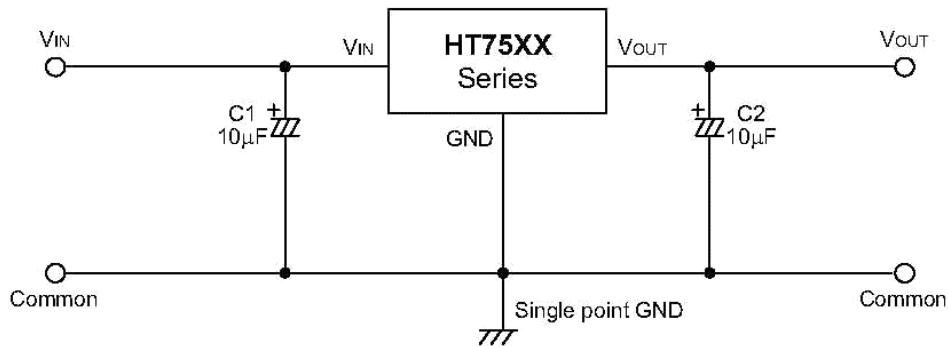

High output current positive voltage regulator

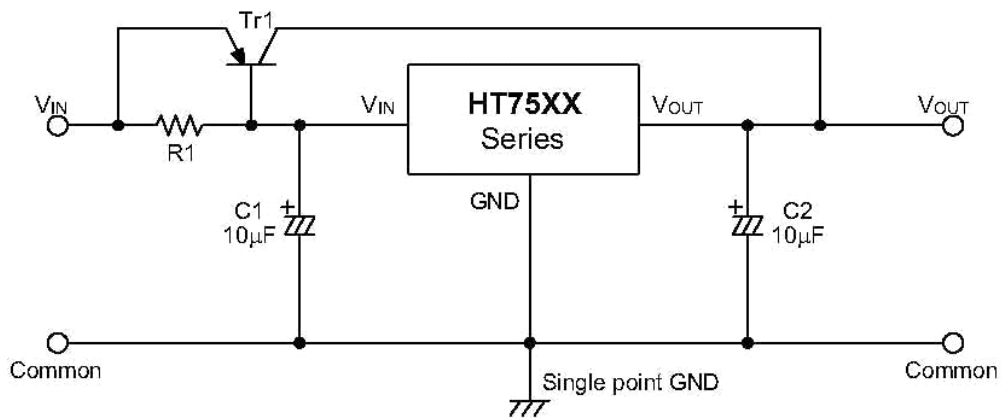

Short-Circuit protection for Tr_1

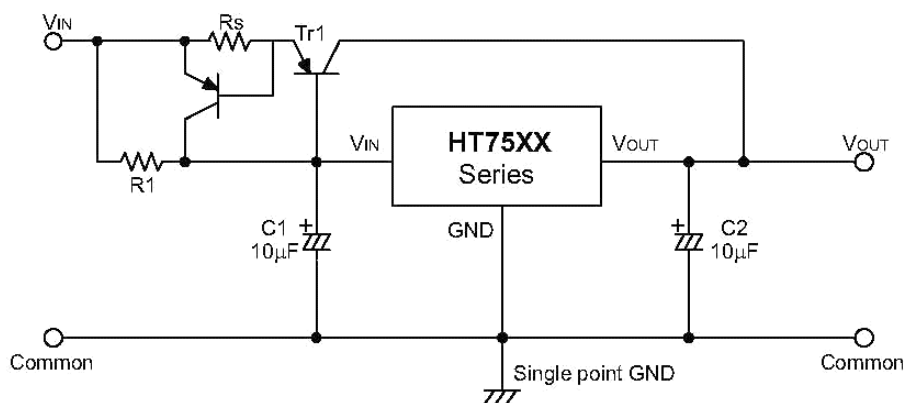

Circuit for increasing output voltage

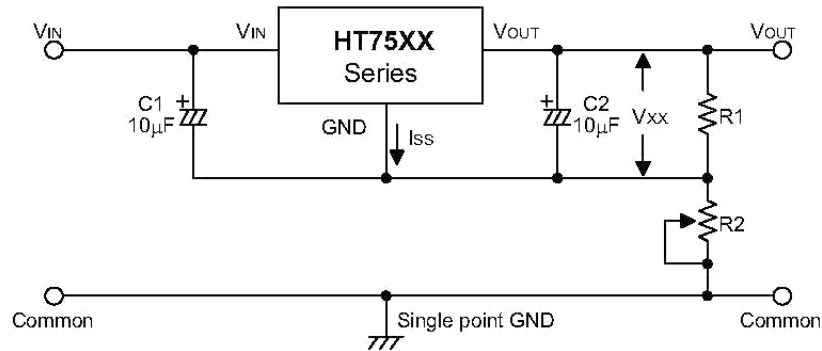

$$V_{OUT} = V_{XX} \left(1 + \frac{R2}{R1} \right) + I_{SS} R2$$

Circuit for increasing output voltage

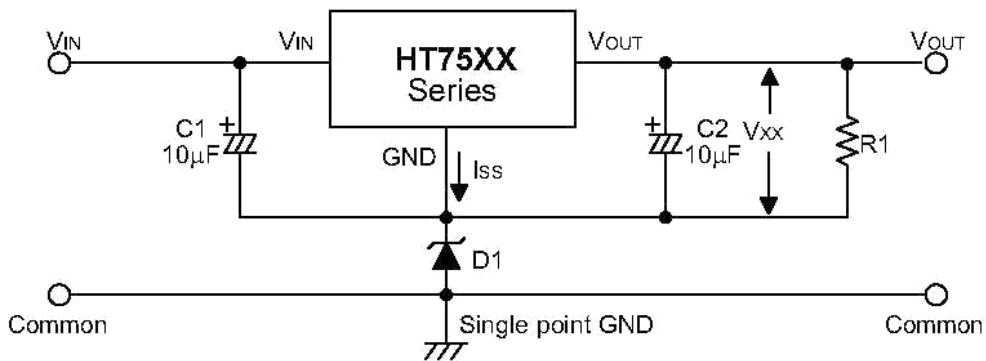

$$V_{OUT} = V_{XX} + V_{D1}$$

Constant current regulator

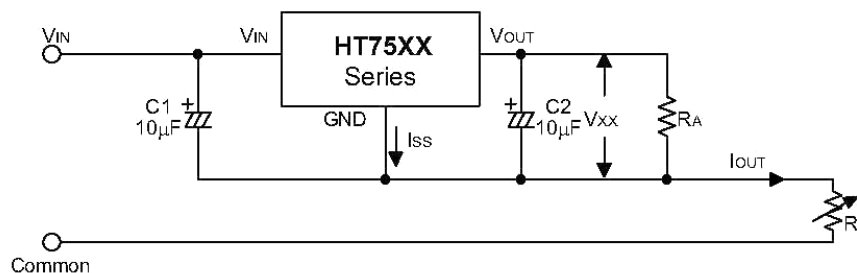

$$I_{OUT} = \frac{V_{XX}}{R_A} + I_{SS}$$

Dual supply

